

siteco

Quantum leap
mast solutions.



Unmatched ease of use.

We have rethought mast solutions. With innovative telescopic and raise and lower masts.

A revolution for installation and operation. Minimum effort for mounting at maximum speed. SITECO mast solutions require neither cranes nor helicopters. This also applies to maintenance and servicing.

Simply lower the masts and work on the floodlight system in comfort. With heights from 6 m to 60 m, we have the right solution for every sports ground.

Up to **80** %
lower maintenance
and installation costs.

Only **1** person
for annual maintenance.

No crane or
helicopter
for the installation and maintenance.





HALIDAY
LIFTING

Static Masts.

- Standard specification.
- Versatile: different designs and customer-specific solutions possible.
- Cost effective.

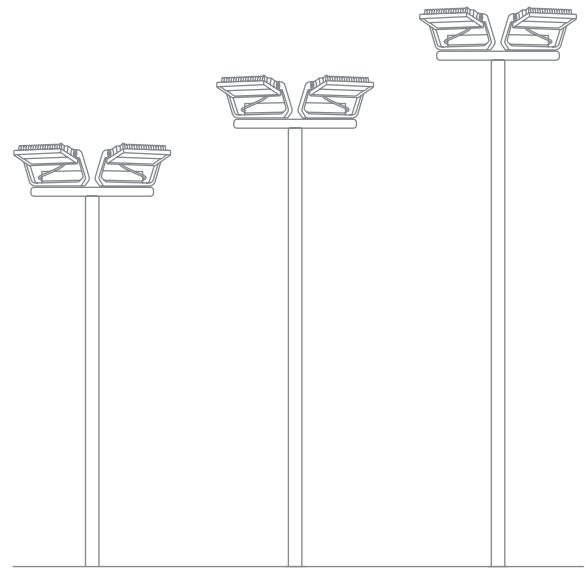

Telescopic Masts.

- Easy handling and low impact on the environment: masts can be lowered to 2.5 m for easy maintenance or when not in use.
- The right solution for any space, thanks to adjustable heights.



How telescopic masts can benefit your sports facility.

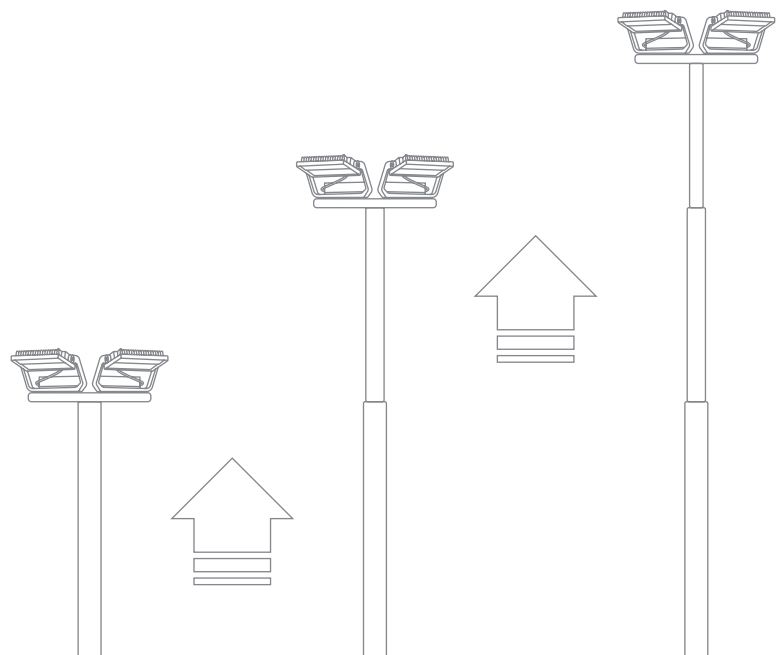

Raise and Lower Masts.

- Safe maintenance and servicing of the system: work can be carried out close to the ground without the use of a lift or crane.
- Cost-effective and flexible: maintenance / repair work can be carried out quickly and without the use of heavy machinery.

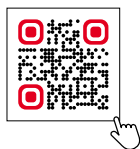

How raise & lower mast solutions can benefit your sports facility.

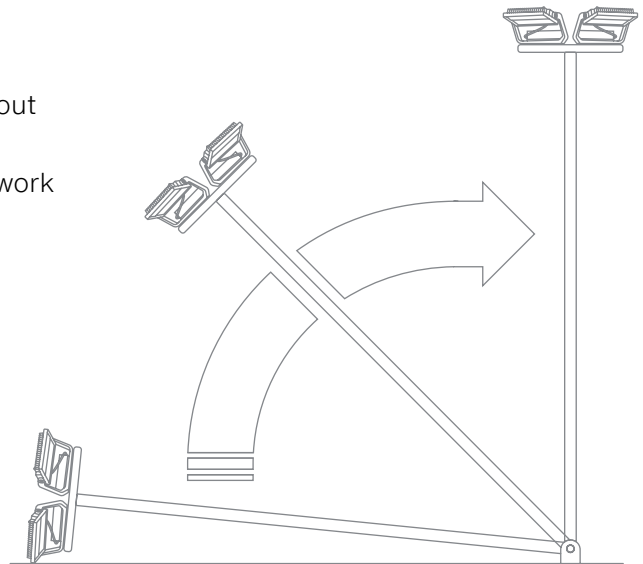

Foundation design

Inhouse foundation design and engineering for different foundation types.

- Spreader foundation.
- Pier foundation.
- Root mounted foundation.

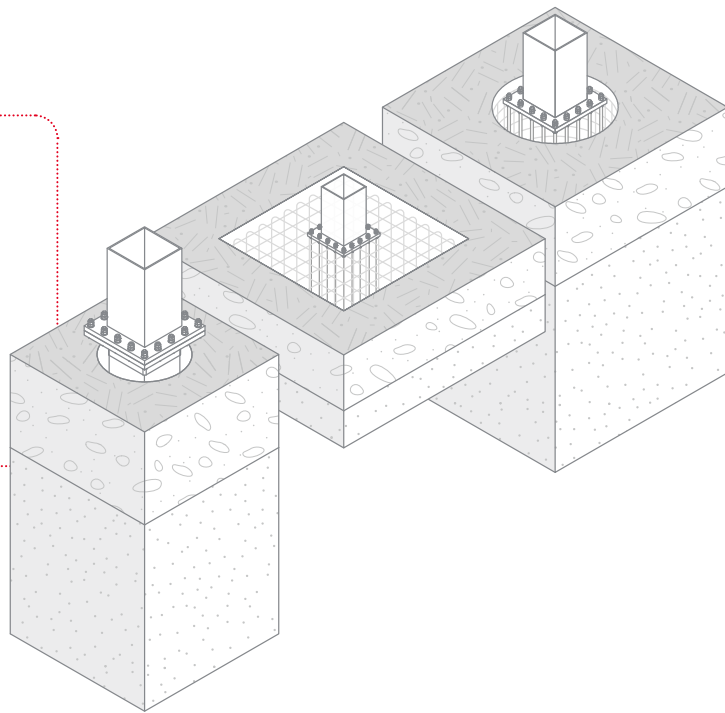

Our raise and lower masts portfolio.



Technical data

Height: 15.6 m
Maximum number of FL 11: up to 3
Maximum weight: up to 124 kg
Maximum wind area: up to 0.98 m ²
Order no.: 5NYHALRL151

Technical data

Height: 15.6 m
Maximum number of FL 11: up to 4
Maximum weight: up to 176 kg
Maximum wind area: up to 1.44 m ²
Order no.: 5NYHALRL152

Calculation of the technical data is based on the following assumptions:

- Wind zone 1 (wind speed = 22.5 m/s).
- DIN EN 40.
- Terrain category 2, max. terrain height of 800 m.
- Maximum number of FL 11 based on an angle of inclination of max. 10 degrees.



Technical data

Height: 18 m
Maximum number of FL 11: up to 7
Maximum weight: up to 296 kg
Maximum wind area: up to 2.5m ²
Order no.: 5NYHALRL182

Technical data

Height: 20 m
Maximum number of FL 11: up to 4
Maximum weight: up to 184 kg
Maximum wind area: up to 1.51m ²
Order no.: 5NYHALRL201

We gladly support you in selecting the optimal mast solution for your specific requirements. Contact us and together we will find the best solution for your project.

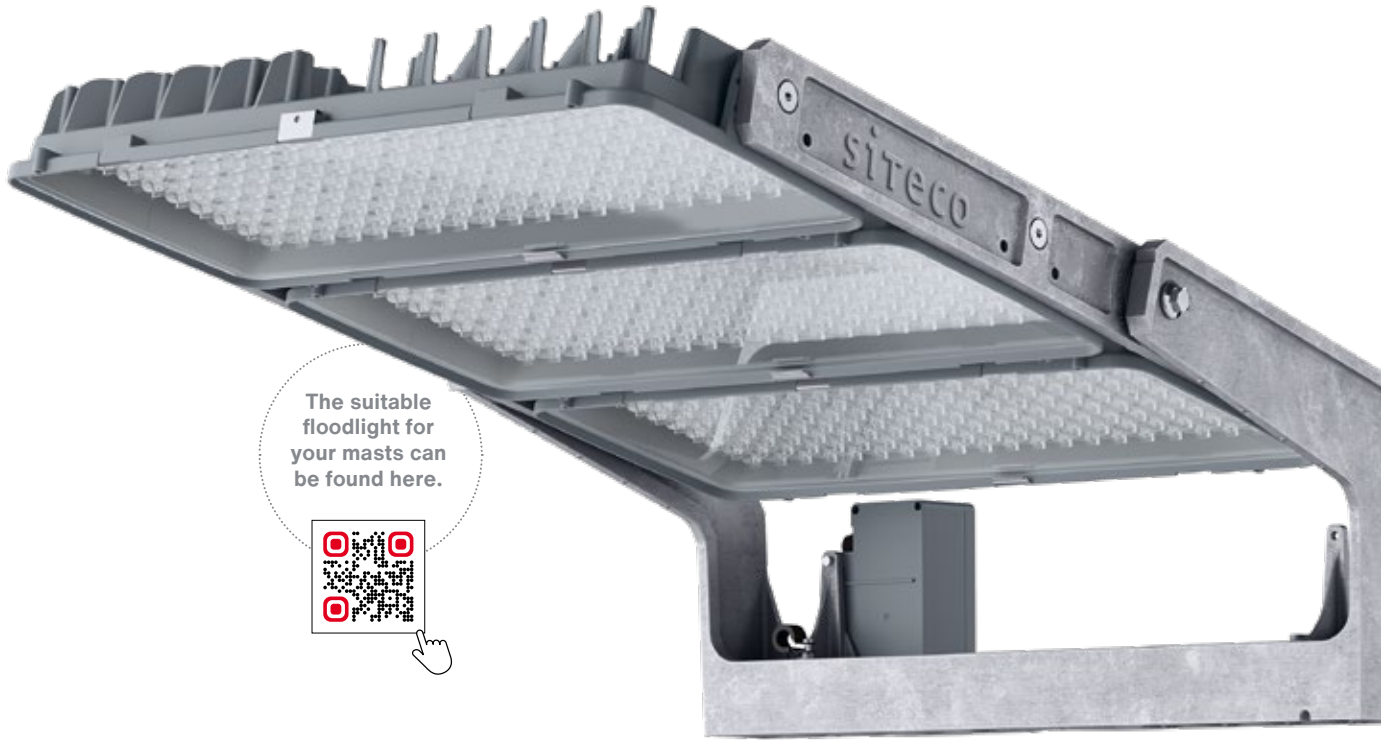

The suitable floodlight for your masts can be found here.



Contact.

George Smith
Product Manager Masts
g.smith@siteco.co.uk

siteco.com

No capacity?
We take on
your project -
turnkey.

