

siteco

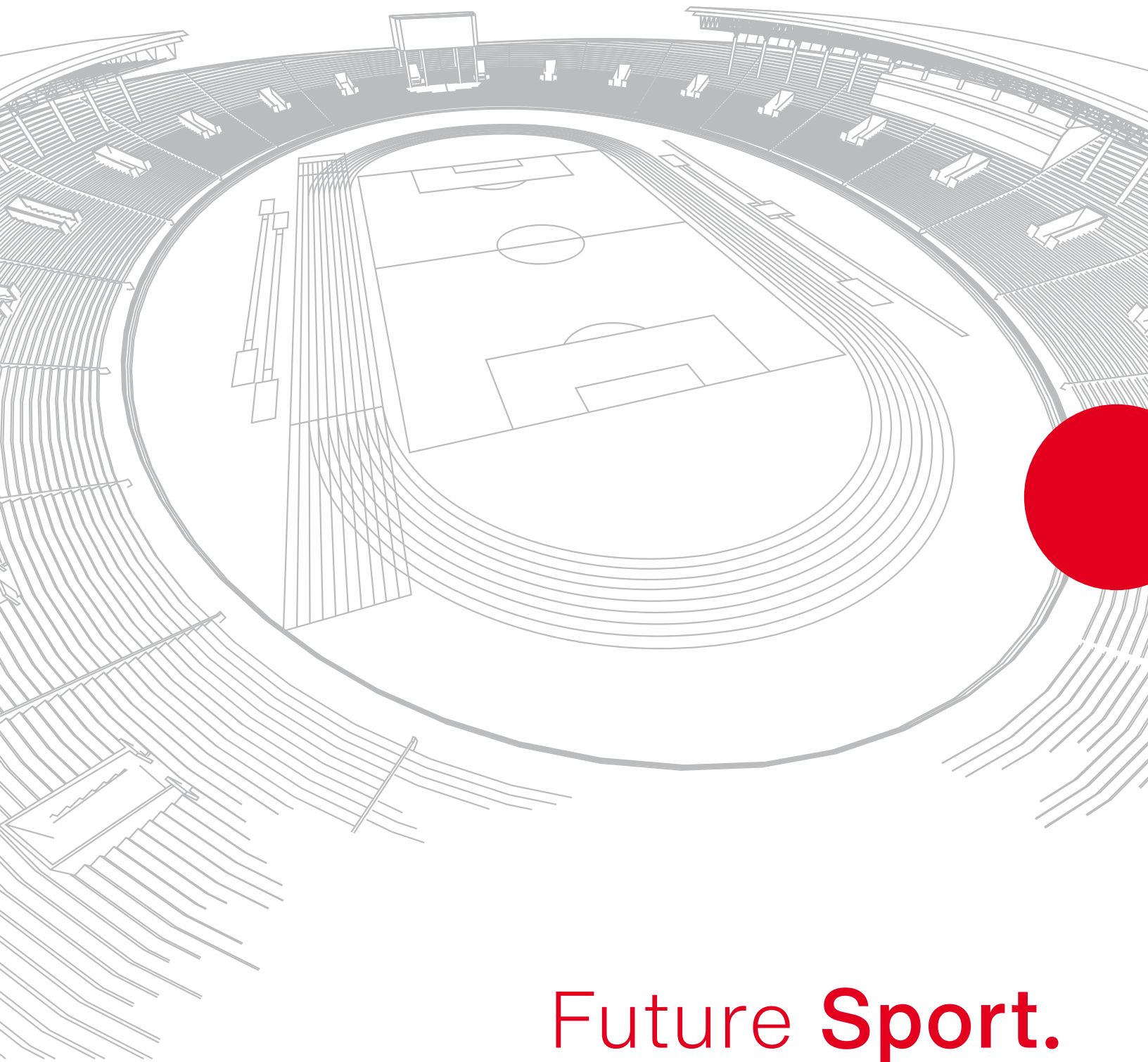

Future Sport.

We take responsibility for your light -
lighting technology designed and engineered in Germany.



Future Sport.
Quantum leap
lighting solution.



Quantum leap lighting solution.

Everything is different with lighting solutions from a single source. The installation and operational knowledge of sports facilities is critical to the development of lighting solutions.

Our products and services are focused on efficiency, modularity and intelligence. With unique know-how, technological finesse and unrivaled vertical integration. Made in Traunreut, Germany.

SITECO stands for a quantum leap in lighting solutions: lighting, control, project and operation.

Click here to experience the event.



Project: SC Verl, Germany

Product: Sirius

SPORTCLUB ARENA



Unforgettable events with minimal environmental impact.

The perfectly staged sporting event. Intelligently controlled light creates atmosphere and pure emotion. Thanks to full cut-off technology, without disturbing the environment.

SITECO lighting technology means ultra strict light control, significantly reducing any obtrusive light. Our high performance Sirius floodlight reaches 0 % upward lighting overspill ratio on the horizontal axis.

Our SIRIUS technology was selected by SC Verl, as the stadium is located in the middle of a residential area. The superior glare control and full cut-off technology significantly reduces any impact on the adjacent community.

A quantum leap for the environment and sport.

0 % ULR light immission with horizontal mounting

100 % atmosphere with intelligent lighting control

Faster, safer, more cost-effective installation, service and maintenance with our unique mast solutions.

The perfect sports lighting solutions require an innovative mast product. Our telescopic and base hinged lighting masts offer smoother and safer operation throughout the life of the installation.

Minimum effort for assembly at maximum speed. SITECO mast solutions require neither a crane nor a helicopter. And that also applies to maintenance and servicing. Simply lower the mast and work conveniently on the floodlight system. With heights from 6 m to 60 m, we have the right solution for every sports field.

A quantum leap for installation, maintenance and servicing.

Up to
80%
lower maintenance
and installation costs

Only
1 person
for the annual maintenance

No crane or
helicopter
for the installation and maintenance





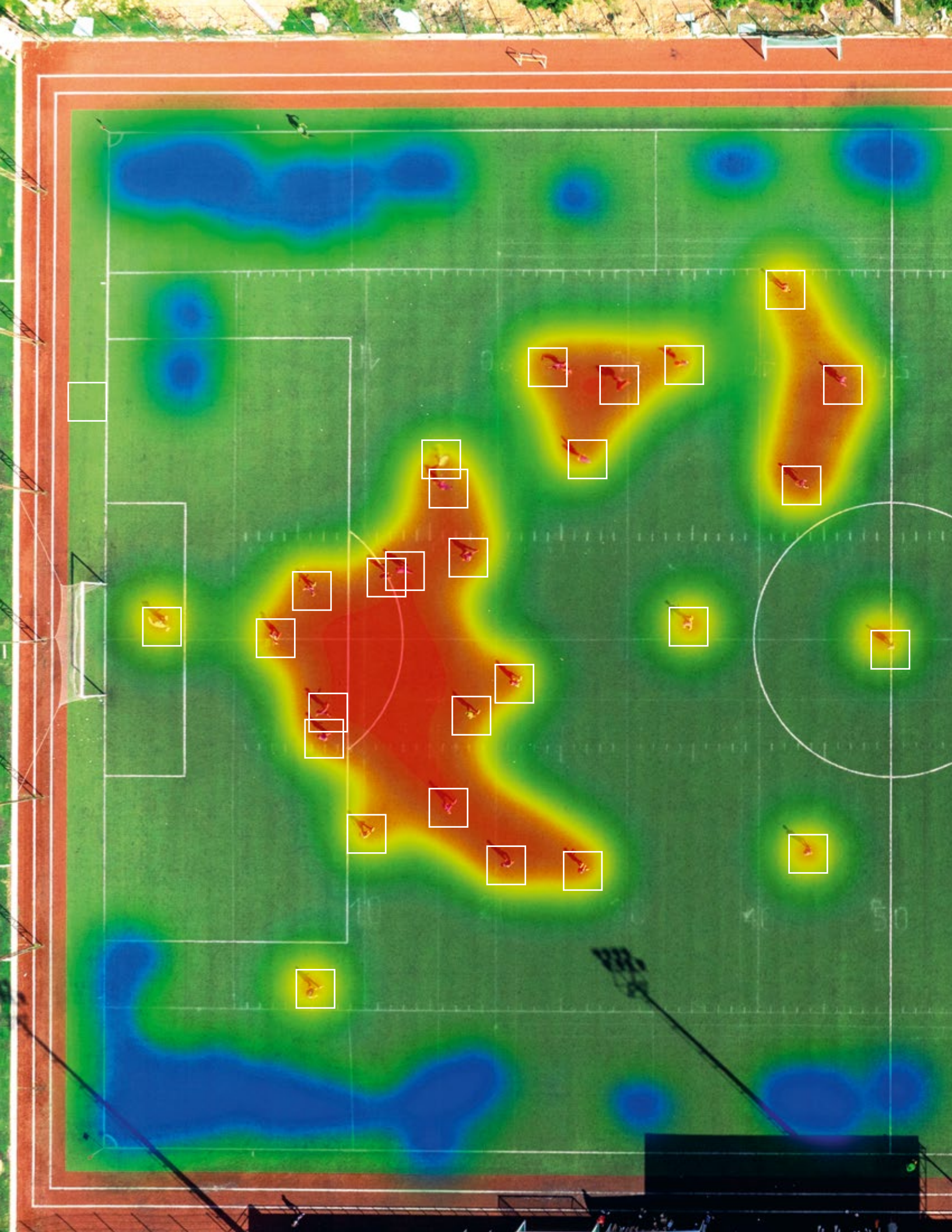



“Just the idea of Genius was impressive all around. To have something track the field, track all the usage and everything that crosses the surface from people to carts to equipment, the ability to take that and turn it into data and create maps of where we’re getting heavy traffic use is music to my ears.”

Nick Pappas, head groundsman at the Mercedes-Benz Stadium, Atlanta

“The world’s smartest sports field.”

Sports fields cost money. Looking after and protecting your investment to ensure your field performs consistently and lasts well throughout its lifespan is vital.

Intelligent Play takes away the guesswork and uses real-time data, tracked automatically from your field to allow you to identify what activities are needed to manage and maintain the field appropriately. For perfect playing conditions, a longer service life, minimum risk of injury and sustainable operation.

The Mercedes-Benz Stadium, home to the NFL franchise Atlanta Falcons – like more than 200 other sports operators – has been relying on Intelligent Play since 2019.

Play better. Last longer. Play safer. Be greener.

A quantum leap for operating and using sports facilities.

Saving CO₂ and energy in a new dimension.

It has never been more important to take a big step. Both for the environment and for your own household. By radically reducing carbon emissions and energy costs.

Our outstanding lighting technology and groundbreaking innovations reduce carbon emissions and operating costs to a new dimension. Above all, the highest photometric efficiency of up to 170 lm/W. The unique use of silver reflectors increases efficiency by up to 11 %, and our patented constant luminous flux technology CLO 2.0 saves up to 7 % energy.

Investing in excellent lighting quality has never been more worthwhile due to exploding energy prices. There are also extensive government funding opportunities. Harborough Town F.C. seized the chance: It relies on the FL 11 and has reduced its emissions and operating costs by well over half.

Up to
80% reduction of CO₂
and energy costs





Project: Harborough Town F.C., England

Product: FL 11

Maximum independence.

Independence is everything for us. In developing our lighting solutions, from the turbulence of international value chains, for reliability for our customers. Because we want to have it in our own hands. Our home advantage: Made in Traunreut.

This is where over a century of pioneering spirit and know-how meets a unique vertical integration. In the development and production of our own lens and reflector optics, our luminaire electronics, modules and iQ control units, our modular luminaire design, and our own sixData and Intelligent Play software solutions. We develop and manufacture innovations for the light of the future.

A quantum leap in independence and innovation.

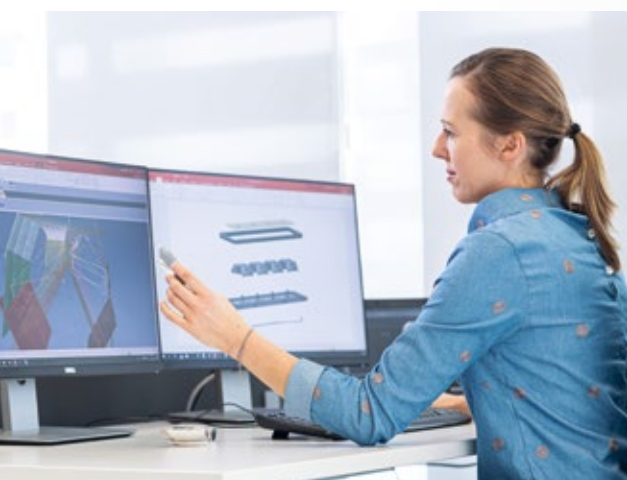

Made in Traunreut, Germany 
Maximum vertical integration
meets infinite configuration
options



100% in-house development
& production

100% modular
product concepts

100% customizability
& interchangeability

Infinite flexibility.

Nothing is impossible for us. We see ourselves as problem solvers, as your partner for your lighting solution. With maximum flexibility, short distances and fast response times – that's what we specialize in.

Our floodlights are 100% modular. That is not only the prerequisite for infinite individualization options, but also for maximum longevity. Because all components can be replaced. That makes maintenance, repairs and upgrades really easy, to keep you at the cutting edge of technology well into the future.

A quantum leap for flexibility and sustainability.

Your single-source lighting solution provider.

It works perfectly. That's all that matters to customers. We assume responsibility for the entire sports lighting solution. Everything from a single source. For the best solution, and to make life as easy as possible for our customers.

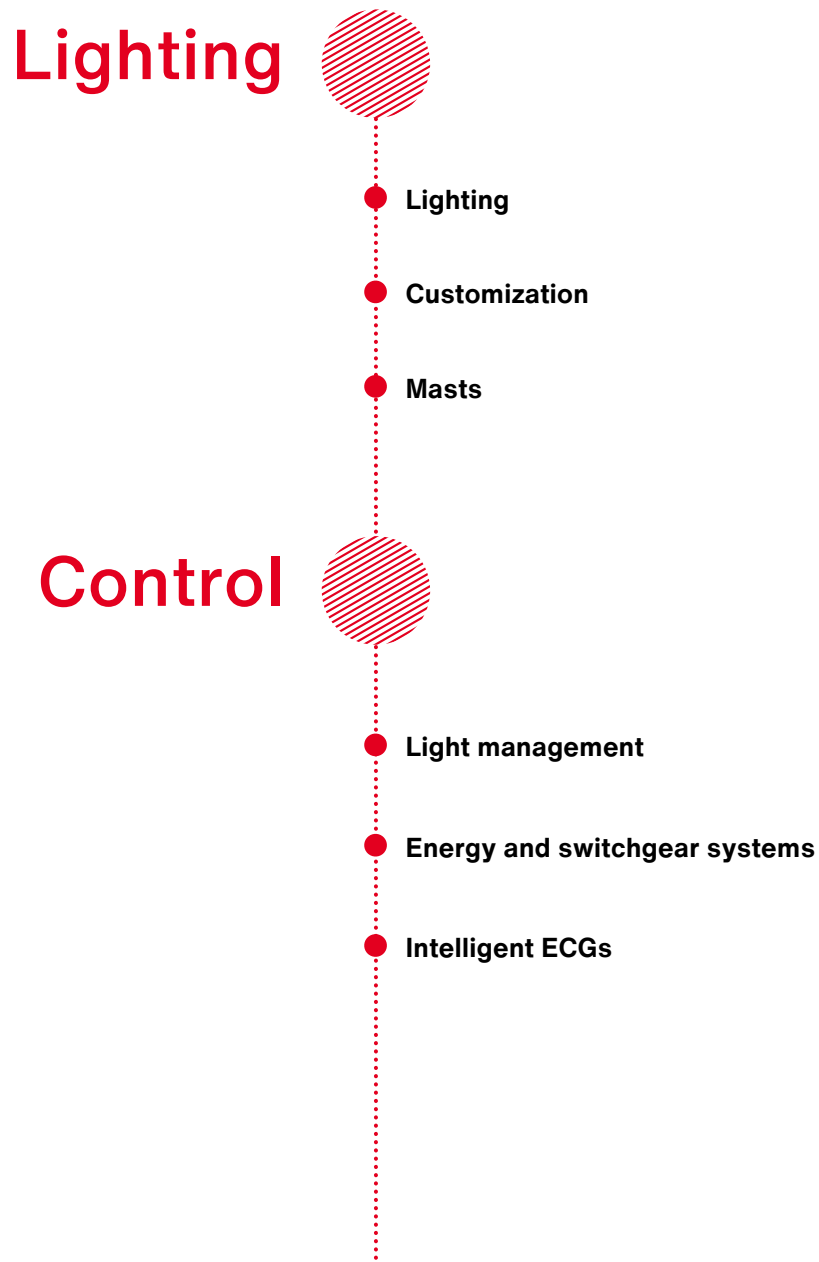

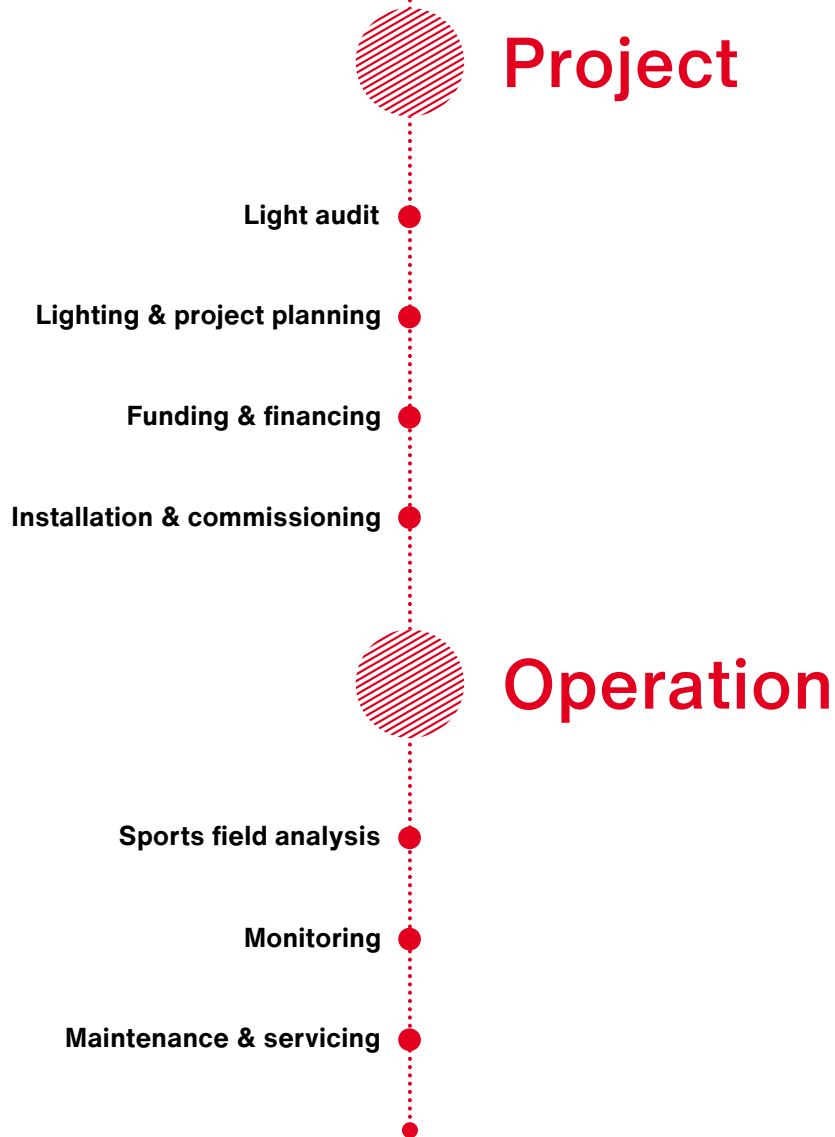

Outstanding lighting technology provides the perfect basis. Lighting control is the prerequisite for unforgettable events and intelligent operation. To ensure that the project is implemented smoothly, we take care of auditing, planning, project management, installation and commissioning. And we also have the right solutions to keep everything running smoothly during operation. Our lighting solutions are modular – you decide how we can support you.

A quantum leap for holistic lighting solutions.

Lighting.

We admit, we love lighting technology.

SITECO is a technology pioneer with more than 160 years of experience. CLO 2.0, full cut-off, free-form reflector technology with a globally unique silver coating. We stand for more than 200 patented lighting technologies with diverse application options for your future.

We also offer you holistic luminaire development from a single source – from the optics, mechanics and thermal design right up to the control electronics. The perfect integration of hardware and software designed and engineered in Germany.

SITECO stands for exceptional lighting technology.

Perfect sports lighting for every application.

Lighting solutions are individual. Whether for a stadium, an arena, or community sports. Whether for the sports field, the changing rooms, or the fan or outdoor areas. Whether for a new build or a renovation. We aspire to provide the best lighting solution for your individual application.

SITECO stands for customized solutions for all sports applications.

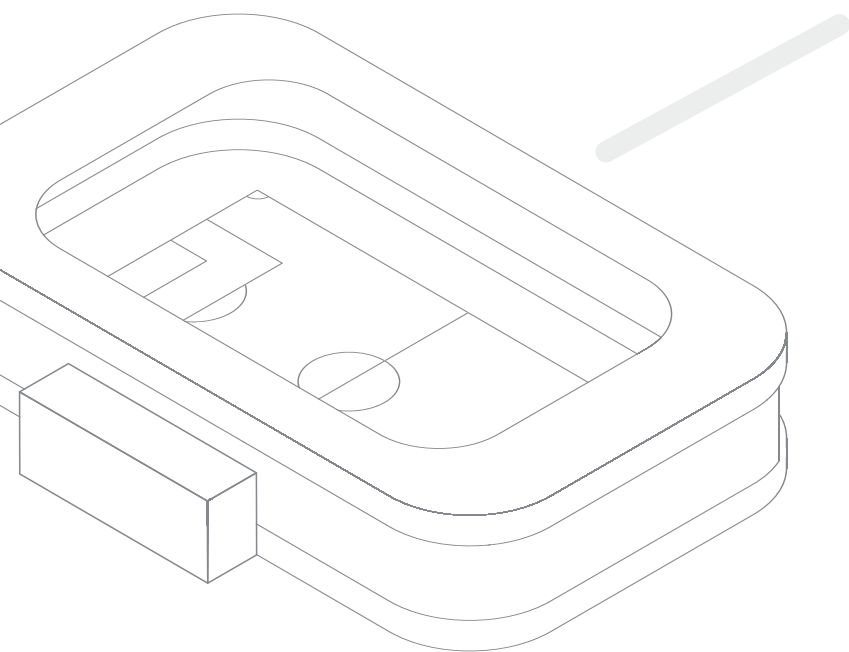

Stadium.

The Champions League of lighting. Professional sporting events require the perfect lighting technology for the perfect HD image.

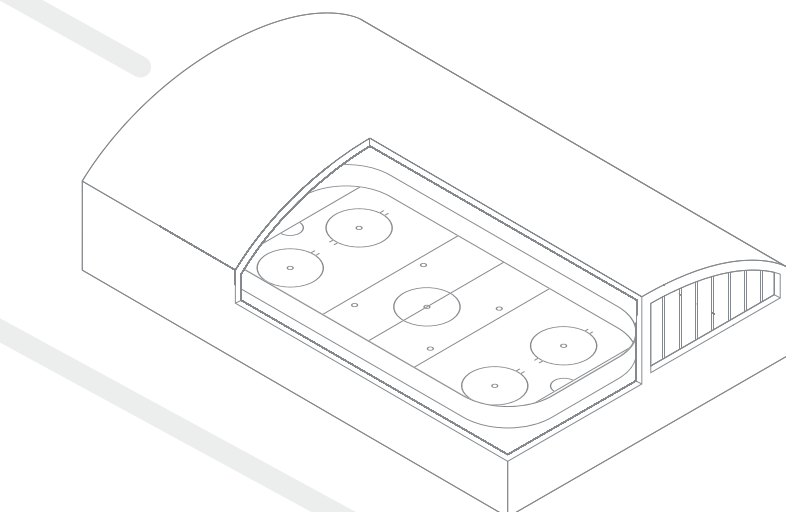

Arena.

Meeting places for a host of sports and events require lighting flexibility. With SITECO, you benefit not only from the best lighting but also from extensive control options.



Community sports.

Whether it's soccer, field hockey, or tennis in amateur leagues, athletes, spectators and residents alike demand optimum visibility without glare.

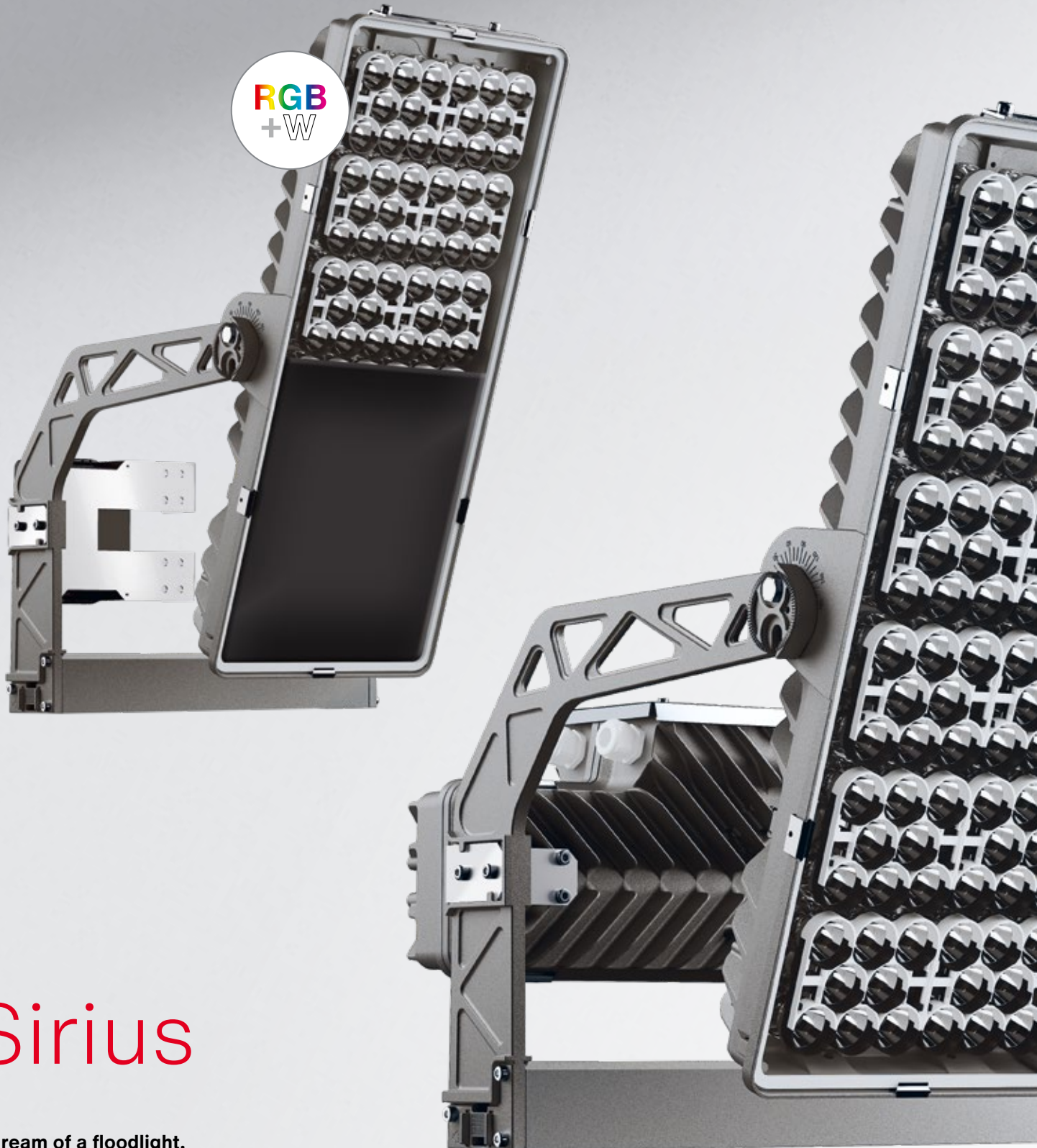

Sirius

A dream of a floodlight.

A revolutionary floodlighting system for sports and event lighting with unmatched performance, efficiency and lighting quality.



Would you like more information about Sirius?



- Full cut-off technology for maximum glare reduction (UGR 10) and perfect visual conditions
- Unrivalled high lumen output with up to 309,000 lm with a long service life of up to 100,000 hours
- Highly efficient thanks to silver reflectors and CLO 2.0 luminous flux tracking
- With a TLCI value of 96 at 5,700 K for true-to-life color rendering and minimum post-editing work
- Modular driver system that can be installed at a distance of up to 150 m and with ECGs that allow separate control of the 4 LED modules – also via DALI / DMX
- Extremely robust with high vibration stability, impact resistance (IK10) and protection rating (IP66)
- Individual intensive color lighting thanks to RGB+W function



Project: Helsinki Olympic Stadium, Finland

Product: Sirius





— Our patented free-form reflector technology enables extremely precise light control with very high optical efficiency.

— The silver coating serves as a multiplier thanks to the significantly higher reflective property of the precious metal.

— The result: Precision down to the smallest facet and > 11 % increase in efficiency.

11 % more performance thanks to unique silver coating.

Reflectors are typically aluminized. Not at SITECO though – We coat our reflectors with silver. Our coating process is unique in the world and, in combination with our free-form reflector technology, it guarantees precision and light quality.

Full cut-off technology for the best view worldwide!

Sirius means the best view – from any seat. Thanks to the unique full cut-off technology, the show can now be experienced with top viewing conditions from any seat. With absolutely no glaring sensation: Sirius offers maximum glare reduction beyond the market standard.

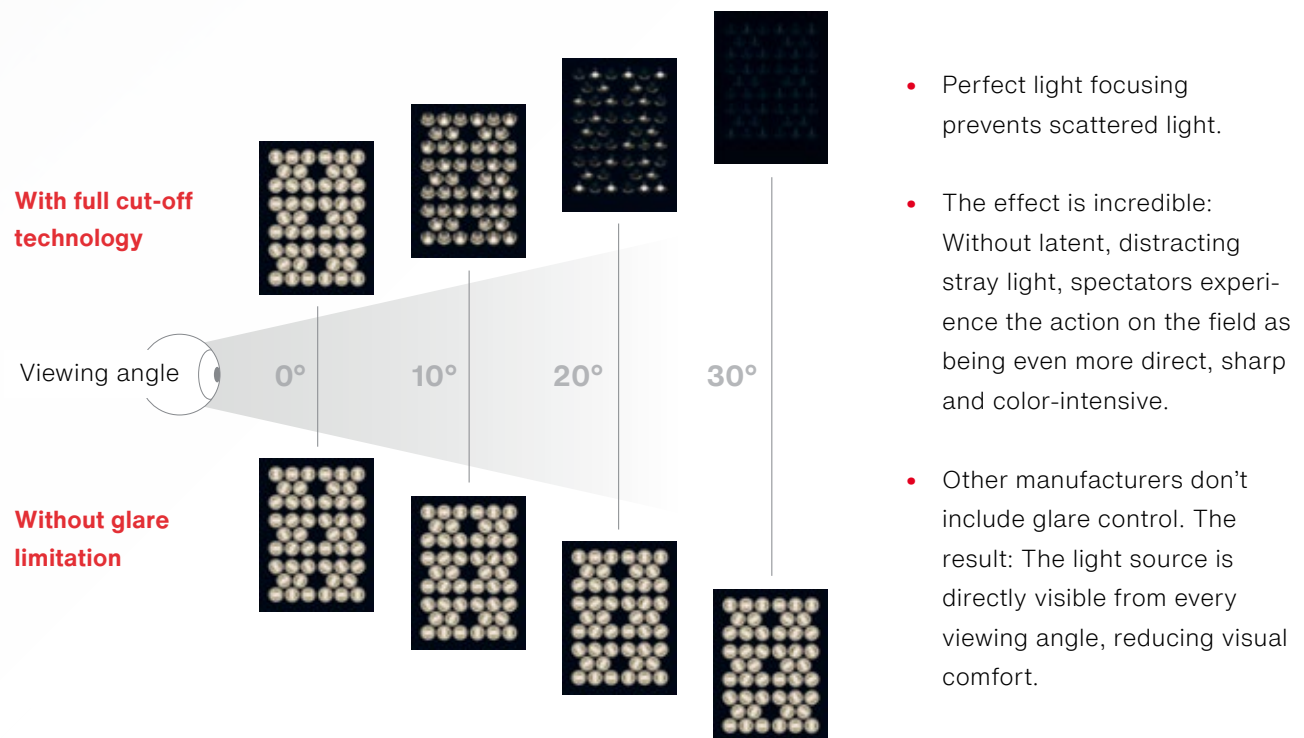



Projectdetails



SPORT SYSTEM

22 WILL MORETON
32 HAJELD ZUIDENA
33 JUVANN JAMES
ESSE MAN
DONAR
10



Project: MartiniPlaza, Groningen, Netherlands

Product: Sirius

DONAR
GRONINGEN

- 1 AGASI
- 3 OGUNGBEMI
- 5 WILLIAMS
- 6 ADETUNJI
- 7 LACY
- 9 RUDEZ
- 14 KOENIS
- 19 BRANDWIJK
- 21 CARUSO
- 22 MORETON
- 32 ZUIDEMA
- 33 JAMES



SAILORS
ALMERE

- 4 VD WEIJENBERG
- 5 VELTMAN
- 6 LOMBARDI
- 7 RICHMOND
- 8 OSEPA
- 9 KAYHAN
- 12 KNEPA
- 13 HERSISIA
- 14 OLIJFVELD
- 16 STRIJDHAFDIG
- 18 POT

- 9
- 2
- 5
- 9
- 2
- 4
- 5
- 2

40 2 16

8:28

- 3
- 4
- 1
- 6
- 2





- Precise, targeted light thanks to asymmetrical light distributions.
- Hugely powerful with up to 250,000 lm.
- Glare-free light with 0 % light immission, without disturbing light for residents and nature.
- Highly efficient operation with a service life of up to 100,000 hours.
- Easy maintenance thanks to flexible ECG integration on the mast or luminaire.
- Maximum flexibility and precision due to rotatable modules and adjustable luminaire head.
- Needs-based light control with DALI, Zhaga, DMX RDM and SITECO Connect Sports.
- High-quality workmanship with non-yellowing PMMA lenses, robust glass covers and die-cast aluminum.

FL 11

More precise and powerful than ever.

With up to 250,000 lumens, FL 11 offers unparalleled light output and sets new standards in brightness and efficiency. Precise asymmetrical light distributions ensure perfect illumination with 0 % light immission. With flexible application areas, the FL 11 is the ideal choice for powerful and environmentally friendly lighting solutions in the sports sector.



Would you like more information about FL 11?



Minimum light pollution thanks to outstanding optics.

Focused application of light improves efficiency and lowers light immission. Thanks to its clever design, the FL 11 requires only minimal tilting and thereby minimizes the unnecessary scattering of light while maximizing light output.

0% light immission. For light where it should be.

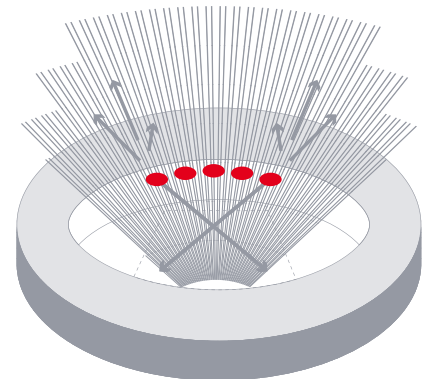

Conventional floodlight systems generate increased light pollution – and therefore adversely affect the environment, neighboring areas and air traffic.

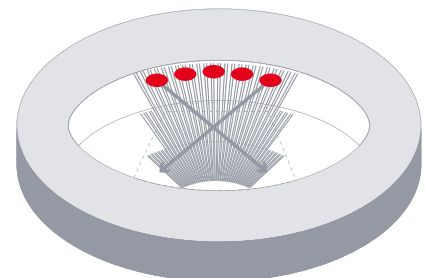

Our optical solutions minimize unnecessary scattering thanks to directed light with minimum tilt.



Project: TSV Poing, Germany

Product: FL 11





0%
light imission

Light – where athletes
need it and spectators
love it.



A new form of green light.

Light sets the pace of our lives. Artificial light can be a real annoyance. It can throw both people and our environment off balance, with devastating consequences for insects and the downstream food chain. With the FL 11, we are setting new standards for nature. After all, light has a special responsibility to assume where spaces used by people and animal habitats are close together.

0% light immission

Thanks to its new asymmetric light distributions, the FL 11 casts light onto the playing field – and only there – with pinpoint and targeted precision. Without stray light and light immission, the night sky remains dark. and nature and residents undisturbed.

Insect-friendly light

The warmer the light color, the less it attracts insects. FL 11 offers particularly insect-friendly light colors with 3,000 K. All types of animals benefit: insect predators, migratory birds, and even fish and amphibians that live near human settlements.

Particularly insect-friendly
option with

3,000 K



Project: Tennis-Club Schaan, Liechtenstein

Product: FL 20



The master of adaptation.

No two sports facilities are the same and therefore neither should the lighting solutions. The floodlight FL 11 has a modular design, so it has maximum flexibility to meet the widest range of needs – from planning to assembly and illumination.

Free placement of the ECG

Compact on the luminaire or placed freely on the mast – you decide where the best place is for the driver. But one thing is certain: The remotely positioned ECG turns every maintenance job into child's play.

Free choice of connection

230 V or 400 V? Both, of course! You do not have to decide before you place an order. The FL 11 floodlight is equipped with a variable ECG that allows both connection options.

Free adjustment

The modules of the FL 11 rotate through 360°. The light head itself can be adjusted in 2.5° increments. That means you can point the light beam with the utmost precision to satisfy your specific needs.

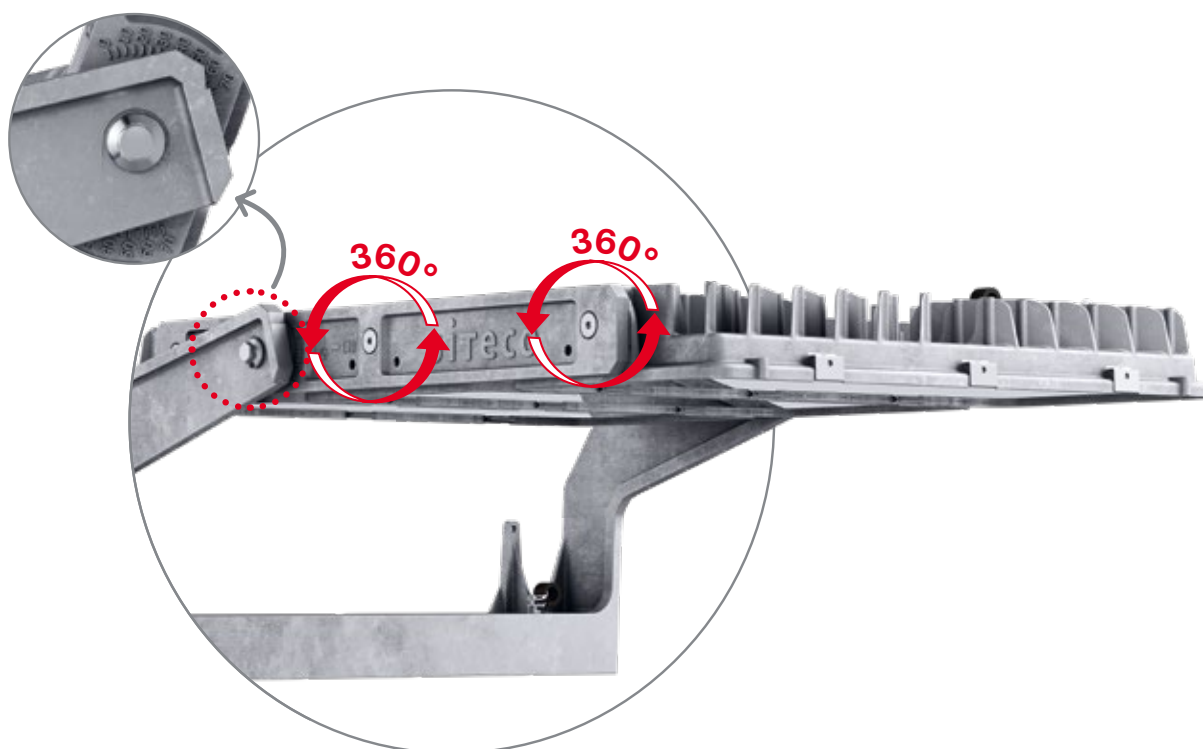

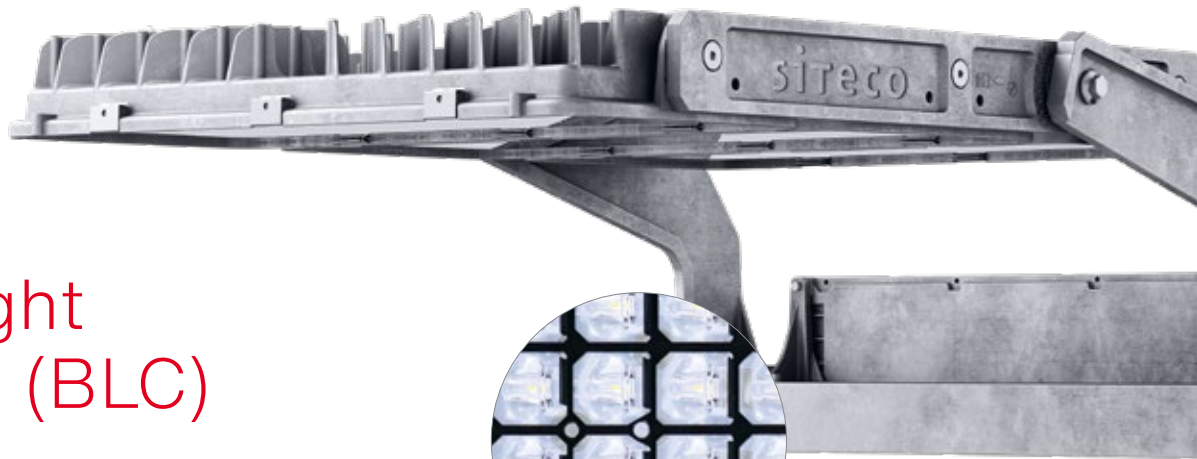

Backlight control (BLC)

Our internal backlight control reflector significantly reduces obtrusive light overspill. Resulting in illumination which is even more precise.

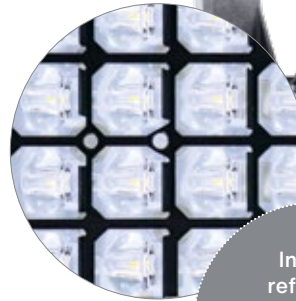

Interior reflector:
No additional wind load, no static problems

Light distributions for FL 11:

<p>1</p> <p>PL64 - to narrowly distribute light on town squares</p>	<p>2</p> <p>PL33T - to illuminate corners</p>	<p>3</p> <p>PL52 - to illuminate wide streets and parking areas</p>	<p>4</p> <p>PL61 - to illuminate streets with widely separated light points</p>
<p>5</p> <p>PL43 - to narrowly distribute light on town squares</p>	<p>6</p> <p>RS07 RS08 RS12 - for long distances in stadiums and halls</p>	<p>7</p> <p>RSD11 RSD12 RSD13 - for long distances in stadiums and halls with maximum luminous flux</p>	



Projectdetails





FL 21

The flexible solution for sports and area lighting at close range.

Limitless flexibility: Whether for sports halls or smaller outdoor sports areas – FL 21 gets to work reliably. More flexible, smart and environmentally conscious than ever before. Three sizes, a range of connection options, adjustments to the product design and brand new control options with SITECO iQ make it happen.

FL 21 – the all-rounder.



Would you like more information about FL 21?



Can be used anywhere: IP66, IK08, CE certified, ENEC certified, D-mark certification, ball-proof (FL 21 midi), suitable for swimming pools.

Durable, exchangeable materials, such as non-yellowing PMMA lenses and glass cover.

SITECO iQ: Comprehensive control and diagnostic options thanks to specially developed luminaire electronics.

Maximum glare control thanks to excellent asymmetric light distribution.

High thermal stability: up to 50° C outdoors, 40° C indoors.

Exceptionally steady luminaire due to high vibration stability. Perfect for outdoor use in very exposed areas.

Extreme snow load stability with a pressure load of 400 kg/m² – that means a snow load zone with snow depths of up to 1.5 m.

Luminaire that preserves the natural darkness of night with 0 % light immission and a warm white light color.



Projectdetails



Project: Skatepark, Karlsruhe

Product: FL 20

Project: Tennis-Club Schaan, Liechtenstein

Product: FL 20



Masts, but innovative.

Sports lighting is more than just lighting. Innovative masts guarantee safety and smooth operation. From 3 meters to over 60 meters high and with different installation and maintenance access, we have masts that meet your lighting requirements.

SITECO stands for innovative mast solutions.

Static masts

- Standard specification
- Versatile: various designs and solutions with the option of designing customized mast solutions

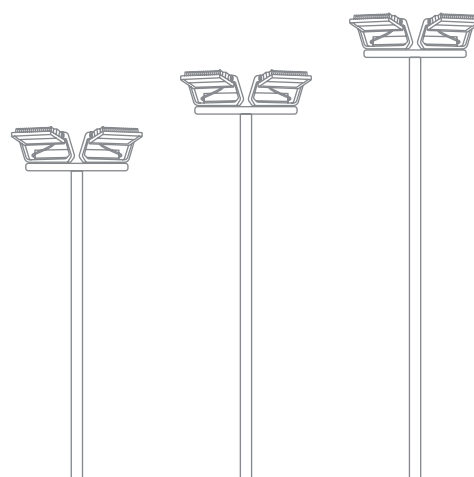

Foundation design

Internal foundation design and development for different foundation types and ground conditions.

- Spread-footer foundation
- Pier-foundations
- Root section foundations

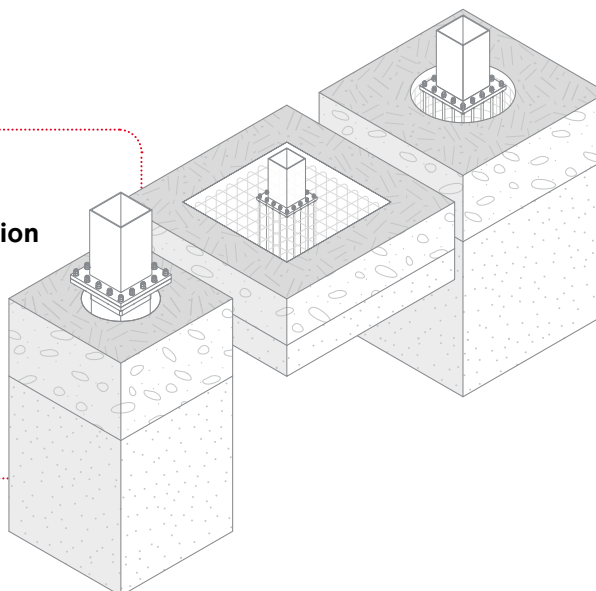

Telescopic masts

- Minor impact on the local environment:
Floodlights can be lowered when not in use
- Easy handling and maintenance of the system/floodlights:
Masts can be lowered to 2.5 m
- The right solution for spaces with strict planning specifications



Here you can see telescopic masts in use.



Base hinged raise and lower masts

- Safe maintenance and servicing of the system: Working at ground level is possible without the use of a cherry picker
- Flexibility and speed: fast completion time for maintenance/repair work
- Time and cost efficient: no heavy machinery required
- Significantly lower lifetime cost

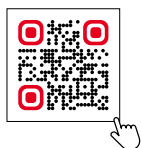

Here you can see base hinged lighting masts in use.

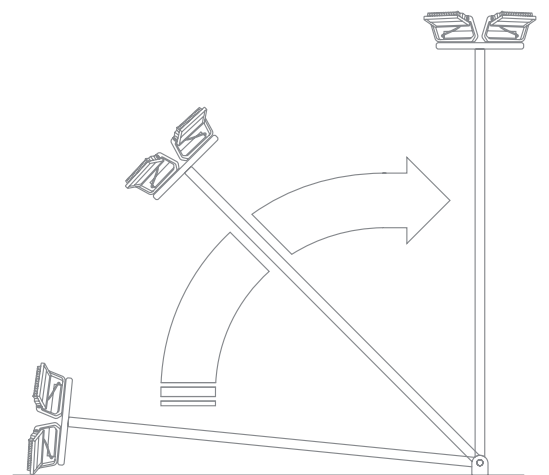

Control.

No debate: Everything has to be possible.

Unforgettable experiences, iconic concerts, first-class sporting events, or daily training sessions: The versatility of modern sports facilities is a key success factor. Intelligent lighting is a key component. For unforgettable emotions, maximum efficiency, and simple operation.

We rely on a unique combination of intelligence. While SITECO Connect opens up the unlimited possibilities of lighting control for you, our specially developed SITECO iQ ECG simplifies operation from day 1.

SITECO Connect and iQ for lighting intelligence².

Control: from intelligent floodlights to intelligent infrastructure.

Intelligent floodlights

SITECO iQ

Automatic data exchange, configuration in the workshop and on the sports field, or control via control line. Maximum intelligence in the floodlight – with intelligent ECG iQ.



Intelligent sports field

SITECO Connect Sports

Flexible dimming, individual control of the floodlights, or personalized scenes. With the control system from SITECO, you always have your sports field under control.



Intelligent field management

Intelligent Play

Intelligent Play uses AI to optimize playing conditions, extend turf lifespan, minimize injury risks, and automate maintenance recommendations.



Intelligent infrastructure

Energy and switchgear systems

Sports fields or arenas: SITECO provides support in the planning and installation of energy and switchgear systems – for a functioning infrastructure.

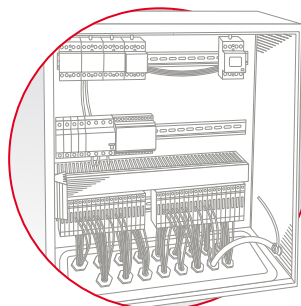

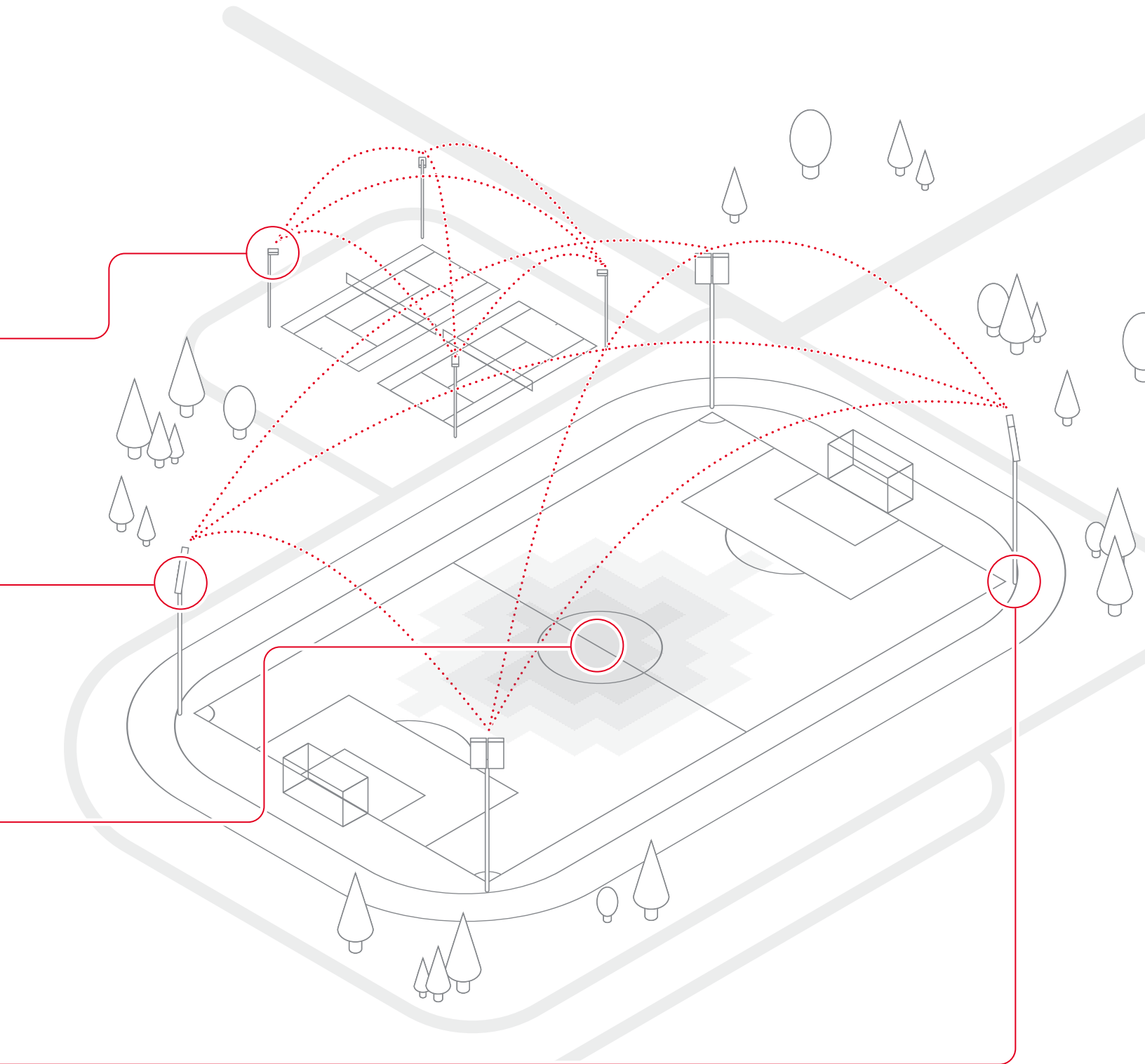

Always the right light. At the touch of a button.

First training on the sports field with dimmed half-field lighting, followed by a derby match with brilliant color rendering for TV broadcasts.

Today, an indoor championship match, tomorrow, the venue for a trade fair. At any time. Our app makes it easy to program and call up personalized scenes.

SITECO Connect Sports for optimum light at every game.

Half-field lighting

Optionally illuminate only one half of the playing field. If you don't need the entire pitch, it will save you energy.

Flexible dimming

100 % illumination across the entire pitch. Dimming is possible according to the needs of the players.

Celebrating a goal

Let the light flicker briefly when a goal is scored (7 s), to create an electrifying atmosphere for players and spectators alike.

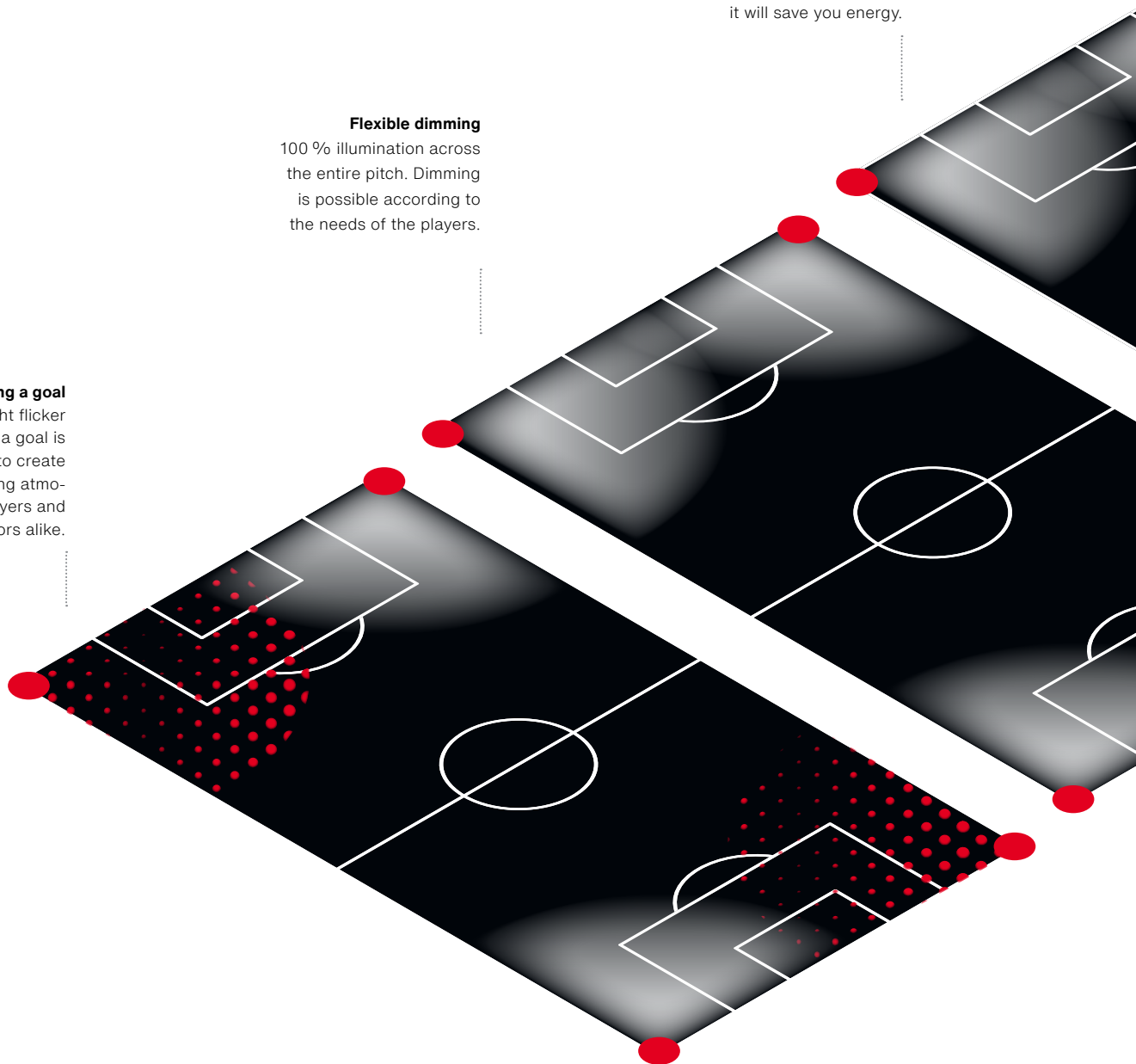

Multifunctional individual lighting

Control a single floodlight.

For example, for a discussion with the team or one-to-one training.

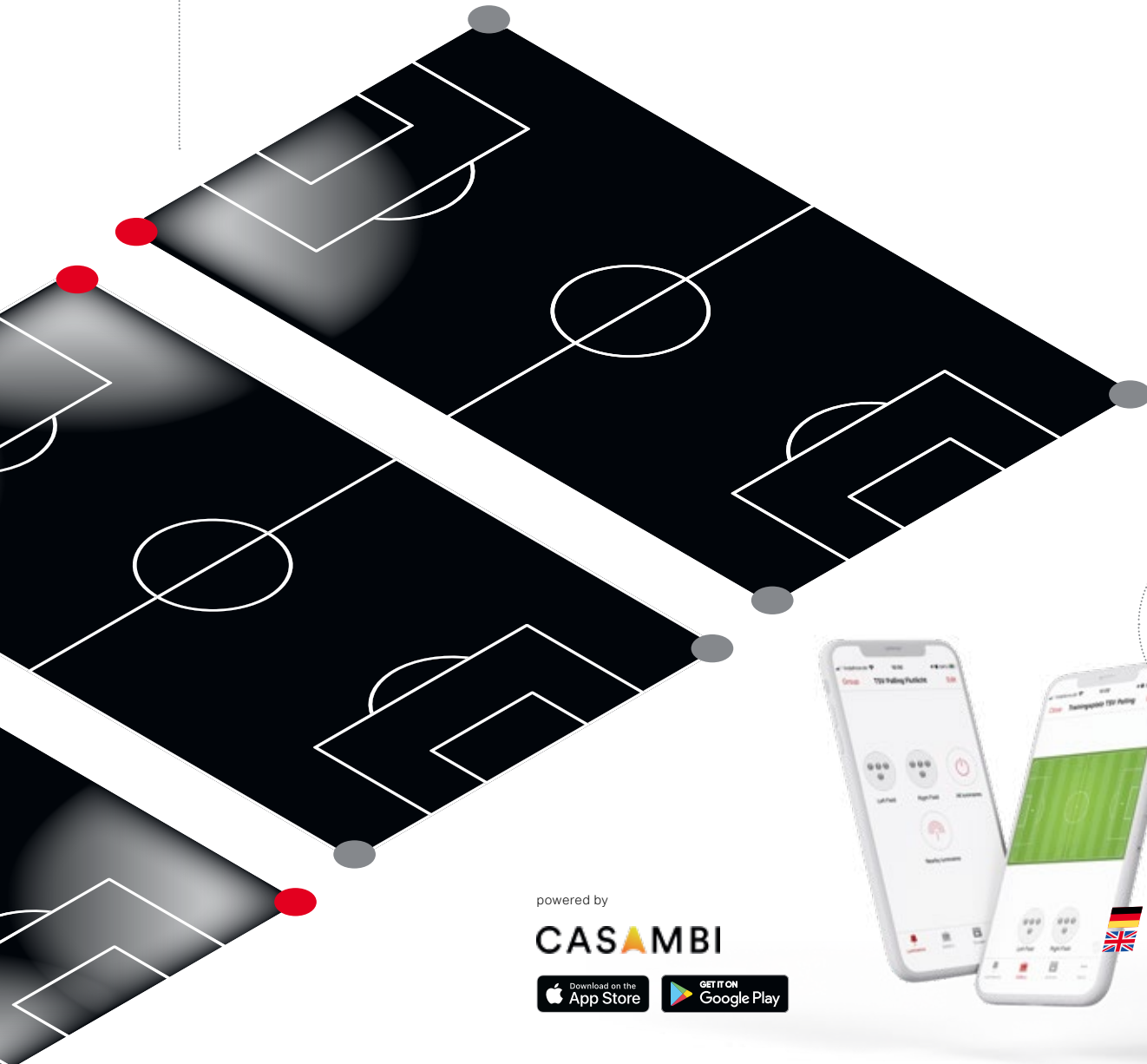

**SITECO
Connect
Sports**



powered by

CASAMBI



- **Simple lighting control** via tablet or smartphone (Android or iOS)
- **Without WiFi and rewiring**
- **Flexible use & configuration** based on your individual needs
- **Maximum energy savings** thanks to adjustable lighting scenes
- **Fully compatible**
- **No license fees**



Project: SV Schwindegg, Germany

Product: FL 11, SITECO Connect Sports



Click
here for more
details about the
iQ functions



Outdoor lighting with the highest iQ.

Intelligence in every luminaire, making life easier for the user. Simply adjust the light, whether in the packaging, on the field, or when replacing components.

With our specially developed SITECO iQ ECG, we are setting new standards for lighting operation.

SITECO iQ - intelligence that makes your life easier.



SITECO **iQ**
**Auto-
Match**

Exchange ECGs in no time,
without any reprogramming.
Saves time and money.

SITECO **iQ**
**Desk-
Remote**

Adjust the luminaire in the
workshop without opening
the luminaire or the box
Simple and uncomplicated.

SITECO **iQ**
**Smart-
Wire**

Dim using existing control
lines and switch between dim
profiles, light colors and
light distributions.

Did you know ...

Unleash the full potential of intelligent street lighting with SITECO iQ sports field lighting. After all, the more complex the requirements, the more important intelligent systems are. And you can operate your outdoor luminaires efficiently, maintain them conveniently, and extend them intelligently for many years.

Project.

How much work can we take off your hands?

Our expertise: Turnkey lighting solutions from a single source. With just one contact person to coordinate the entire project for you and ensure that everything runs smoothly.

Your choice: You decide how much work we can take off your hands. SITECO Service offers modular selection for your project. From a status review in a light audit, planning and project work, installation and commissioning, to the funding and financing of your lighting system.

SITECO Service stands for projects from a single source.

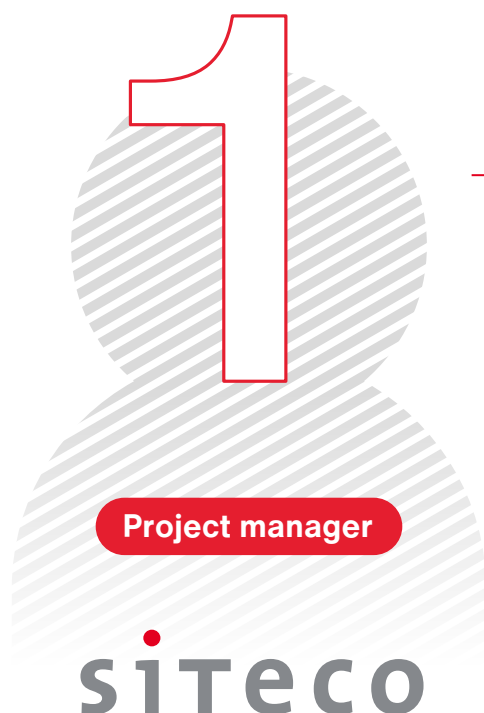

Excellent know-how and only one contact person.

Turnkey projects require excellent know-how – in all disciplines. That’s why we have trained specialists with many years of experience in the electrical industry for each service module. We also have access to a select, nationwide network of partners and subcontractors.

To make your life as easy as possible, at SITECO you have just one contact person to coordinate the entire project. Our project managers assume responsibility for the project from day 1 and therefore guarantee that everything will run smoothly and successfully.

So that everything happens at the right time. So that all partners are well integrated. So that challenges are solved before you’re even aware of them. So that you get your perfect lighting solution easily and smoothly.

Our SITECO service team assumes responsibility for your project.



+ Light audit

+ Planning & project work

+ Application for funding

+ Financing concept

+ Delivery & preparation

+ Installation

+ Commissioning

+ Acceptance & documentation





Light audit: On-site status review.

Needs assessment, tailored to you. Our experts review the status quo and the requirements for your refurbishment or new build on site. Field by square, stadium by stadium. From the lighting to the electrical sub-distribution, we create transparency.

The result: The perfect basis for your new lighting solution and an initial estimate of costs and potential savings.

Our light audit creates transparency:

- Record lighting system requirements
- Analyze system condition and refurbishment requirements
- Operating costs and CO₂ savings
- Investment and payback



Refurbishment: Sample savings calculation for a turnkey 4-mast system.

	Old system	New system
Luminaire type	8 × 2,000W ECG	FL 11 maxi 917W
Annual energy consumption in kWh*	8,800	3,668
Annual operating costs in €	3,680	1,284
Energy	3,080	1,284
Maintenance	600	low maintenance
Annual savings in €		-2,396

* Based on 500 operating hours per year.
Additional savings can be achieved with SITECO Connect Sports.

3t CO₂
saved each year

-70 % cost savings

Up to 40 % funding possible

Lighting and electrical planning: Standard-compliant planning of the new system.

Our experts show you what is possible for your sports facility. We turn ideas and the functional and design requirements into technical solutions.

Our lighting planners, structural engineers and cost accountants work hand in hand with architects, lighting and electrical planners, and installation companies. The result: Customized and standard-compliant planning.

Our customized lighting concept:

- Lighting design
- Lighting and electrical concept
- Customizing
- Mast planning and statics concept





SCHNEIDER

Hagemann

Kattenstroth

Hotel Kampwirth

emas & Polln

teier

ELEKTRO BECKHOFF

IP



Funding: Application for funding.

Our experts help you select the maximum funding for your project and country. We calculate the funding with you and help you with your application. The result: With high funding rates of up to 40 %, the lighting solution will pay for itself faster than ever.

Our funding advice can be found here



Our funding advice:

- Information on funding programs worldwide
- Calculation of the financing effect
- Support with the application

Up to
40 %
funding

Financing: Simply pay in installments.

We dispel your concerns about high investment costs. The systematic modernization of lighting systems usually pays for itself. You save from day 1 with our individual financing solutions. The term is flexible and is tailored to suit your needs.

How does it work? Our video:

Earn money from day 1



Our financing solutions:

- **Flexible terms and installments**
according to your needs
- **Savings from day 1**
without capital expenditure
- **Services such as planning or installation**
by partners can be flexibly integrated

Payback
from day 1

Installation & commissioning: Turnkey implementation.

Everything works perfectly. Our experts take care of everything, on site and behind the scenes, Coordination of the construction site and the subcontractors. Everything at the right time, together with renowned partner companies and partners of your choice.

The result: uncomplicated installation and commissioning of your lighting system on the desired date – turnkey.

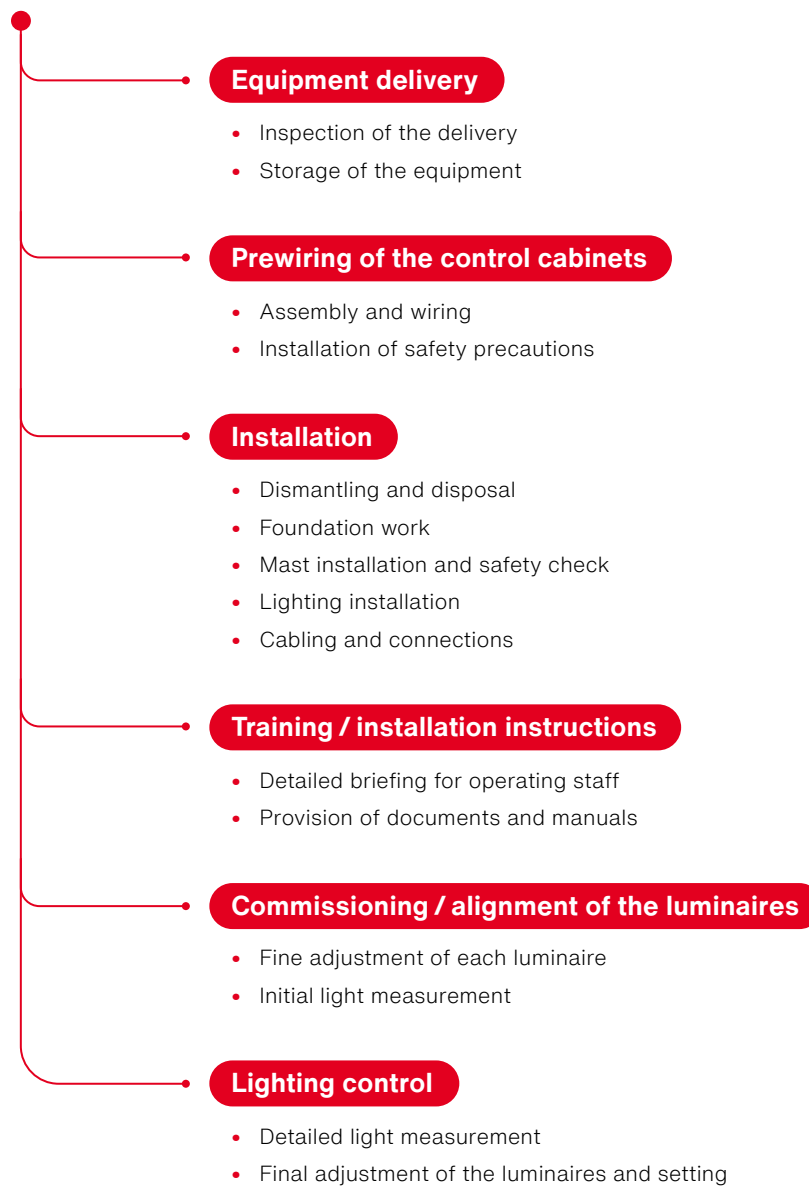

Operation.

We make sure everything runs smoothly.

Perfect lighting, exceptional space conditions. Today, tomorrow, and beyond. To keep it that way, we take over operation for you. We ensure that your lighting functions flawlessly, that lighting conditions remain perfect, and that no efficiency is lost. That faults are rectified immediately. And even ensure that your turf is in ideal condition.

Thanks to our leading operating platform sixData, the artificial intelligence of our Intelligent Play pitch analysis, and our experienced service team, you can concentrate fully on the sport.

SITECO assumes responsibility for operating your lighting system.

Perfect data is the basis for smooth operation.

We document your lighting system in the leading operating platform from sixData. From here, we plan the maintenance, rectify faults, document the implementation, and look after invoicing. Our SITECO service team carries out everything on site.

SITECO takes over the operational management for you.



As lighting experts, we get the most out of your lighting system at all times, and minimize operating costs

Standardized documentation and management with leading digital asset management sixData

Simple planning, implementation, and maintenance documentation

Centralized and digital handling of all processes from commissioning to invoicing

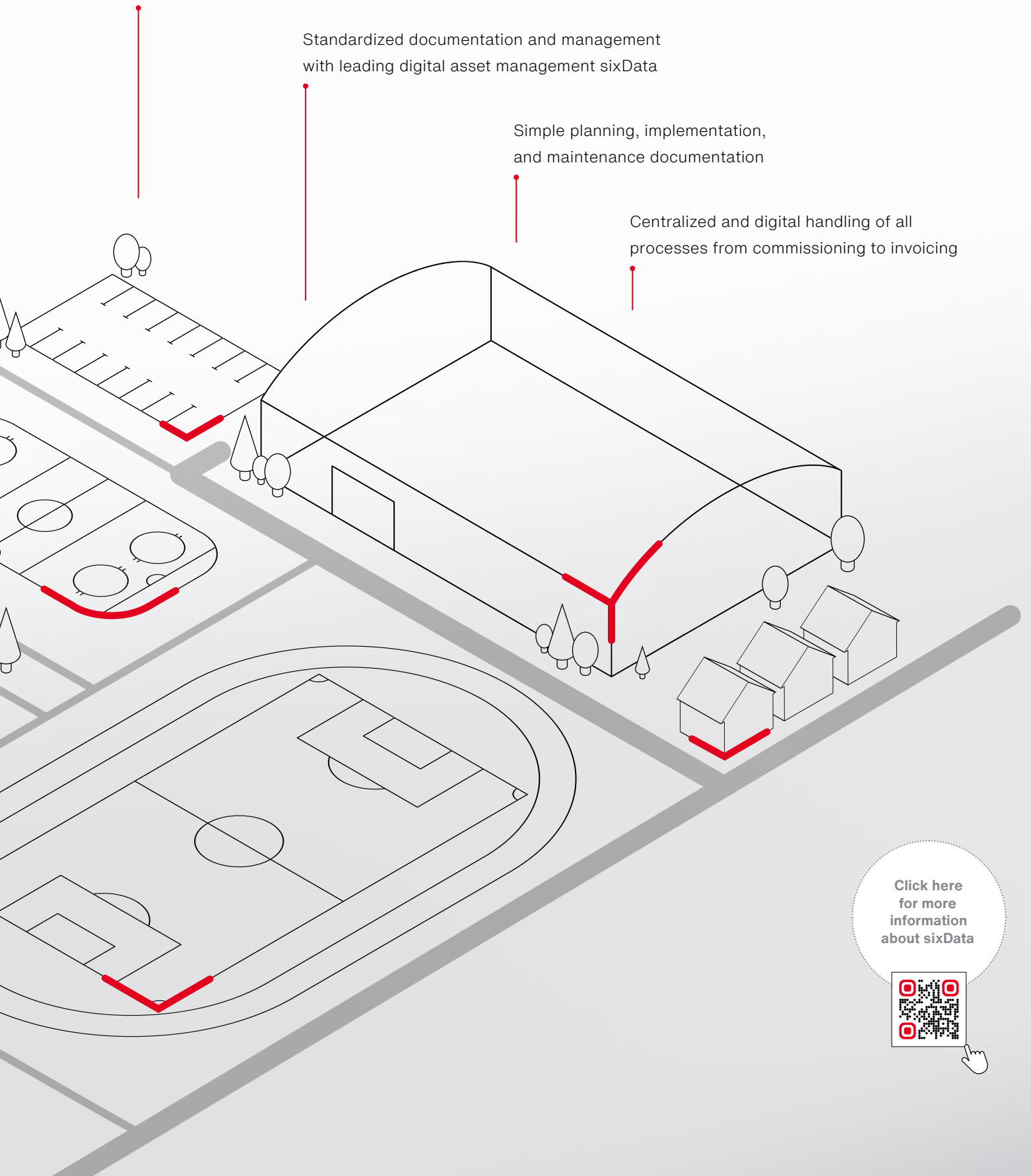

Click here for more information about sixData





Project: Halliday Lighting
product: FL 20



Perfect playing conditions thanks to Intelligent Play.

The goals of Intelligent Play are clear: perfect playing conditions, extended service life, minimum risk of injury, and sustainability down to the last detail. Patented technology based on artificial intelligence is used to analyze usage of the turf in real time. For full transparency regarding the condition of the turf. And automated recommendation for the care and maintenance of the pitch.



Developed to solve problems faced by the owners and management of sports facilities.

Trusted by
thousands of
users globally
at every level



Play
better.

Optimum playing conditions at all times thanks to precise real-time data on turf quality.



Last
longer.

Extended turf life thanks to full transparency regarding the condition of the field, and automated maintenance recommendations.



Play
safer.

Minimum risk of injury to players by identifying high-traffic areas and planning appropriate maintenance and protective measures.



Be
greener.

Maximum sustainability through efficient maintenance, increased productivity and extended turf life.



0044M

Sensor: 605 HWID: 3549

RUTGERS



Project: Rutgers University, New Jersey, USA

Product: Intelligent Play

Maintenance & servicing: for smooth operation.

SITECO is by your side for the long term to ensure that your system functions optimally. With professional maintenance and servicing, we ensure that you can always get the best performance out of your system and can concentrate on what really matters.

- Regular cleaning of the luminaires
- Replacement of defective components and light sources
- Continuous optimization of lighting control for maximum efficiency
- Warranty support



We are grateful for the long-time confidence of our customers and partners. And for the dedication and passionate commitment of all our employees. Together, we enable a quantum leap for holistic lighting solutions from a single source.

Quantum leap
lighting solution.

Outstanding lighting solutions for over 160 years.

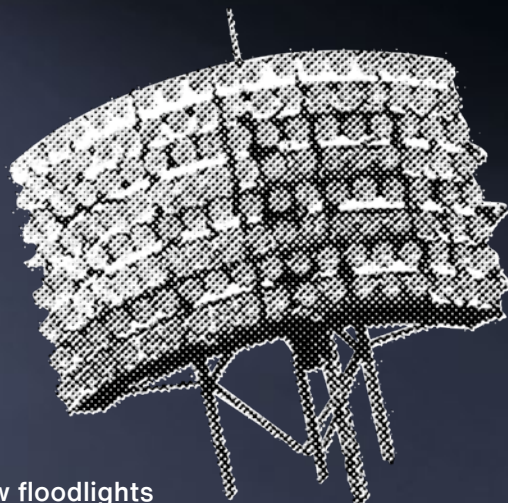

SIEMENS 1862

Siemens & Halske A.G. founded

1971

First 3.5 kw floodlights used at the Olympic Games in Munich

1982

First HCL solution using a daylight system



1882

First street light in Berlin



1962

100 years of Siemens lighting and first lighting test road



1975

1975

First trunking system

1980

1980

First BAP50 louver luminaire

1982

1987

1987

First secondary system as a basis for successful MirrorTec concept



1949

Production in Traunreut



2019

Sirius is the first LED floodlight with TLCI 96

sitEco 1997

SITECO founded

sitEco OSRAM

2011
SITECO becomes part of OSRAM

2023 ...

SITECO becomes leading solution provider

2023
Halliday Lighting becomes part of SITECO



2006/08
First LED office and road luminaire

2022/23
sixData and Bergmeister luminaires become part of the SITECO family



1998
Patent for micro-prismatic technology

2021
IoT revolution: SITECO iQ and Connect become the digital infrastructure of the future

2019

SITECO becomes independent: medium-sized company

sitEco

Stern Stewart Industries

Sales.

Australia

SITECO UK Ltd

Hexagon Tower,
Crumpsall Vale, Blackley
Manchester, M9 8GQ
Phone +44 3300 555 209
contact-uk@siteco.com

Czech Republic

SITECO GmbH

Sokolova 696/32
619 00 Brno
contact-cz@siteco.com

Hungary

Siteco GmbH

Jan Vacek
j.vacek@siteco.cz

Norway

SITECO Norway AS

Engebrets vei 5
0275 Oslo
Phone +47 45 37 71 00
kundesenter@siteco.com

Serbia

SITECO Serbia

Ivan Lazarevic
Dositejeva 1a
11 000 Belgrad
Phone: +381 69 5444 802
i.lazarevic@siteco.com

Sweden

SITECO Sweden AB

Källbäckstrydsgatan 3
507 42 Borås

Benelux

SITECO Benelux

Marten Meesweg 8-10
NL-3068 AV Rotterdam
Phone +31 85 4000 454
contact-nl@siteco.com

Finland

SITECO GmbH, Finnish Branch

Business Park Kehämylly
Vantaankoskentie 14
01670 VANTAA
contact-fi@siteco.com

Italy

SITECO Italy S.r.l.

Via Libero Temolo, 4
20126 Milan
Phone +39 320 0692561
contact-it@siteco.com

Poland

SITECO Poland Sp.z o.o.

Al. Jerozolimskie 94
00-807 Warszawa
Phone +48 22 462 49 30

Slovakia

SITECO GmbH

Jan Vacek
j.vacek@siteco.cz

United Kingdom

SITECO UK Ltd

Hexagon Tower,
Crumpsall Vale, Blackley
Manchester, M9 8GQ
Phone +44 3300 555 209
contact-uk@siteco.com

Bulgaria

SITECO Bulgaria

Andreea Luppá
Phone +40 735 316 760
a.luppá@siteco.eu

France

SITECO France Chez REGUS

7 rue Meyerbeen
75009 Paris
Phone +33 6 24 57 58 61
contact-fr@siteco.com

Moldova

SITECO Moldova

Andreea Luppá
Phone +40 735 316 760
a.luppá@siteco.eu

Portugal

SITECO Portugal

Cesar Campos
Phone +351 91 171 44 85
contact-pt@siteco.com

Slovenia

SITECO GmbH

Trg republike 3
1000 Ljubljana, Slovenija
contact-si@siteco.si

Other Countries

SITECO GmbH

Georg-Simon-Ohm-Straße 50
83301 Traunreut, Germany
Phone +49 160 935 77095
contact-export@siteco.com

Croatia

SITECO GmbH

Radnička cesta 80
10000 Zagreb
contact-hr@siteco.com

GCC Countries

SITECO Lighting LLC

Phone +97155 5107860
contact-uae@siteco.de

New Zealand

SITECO UK Ltd

Hexagon Tower,
Crumpsall Vale, Blackley
Manchester, M9 8GQ
Phone +44 3300 555 209
contact-uk@siteco.com

Romania

SITECO Romania

Andreea Luppá
Phone: +40 735 316 760
a.luppá@siteco.eu

Spain

SITECO Lighting Spain, S.L.

Av. Leonardo da Vinci 15
28906 Madrid
Phone +34 9100 29095
contact-ES@siteco.com

Contact.

Siteco GmbH

Georg-Simon-Ohm-Str. 50
83301 Traunreut, Germany
Phone +49 8669 330
info@siteco.com

[siteco.com](https://www.siteco.com)

Click here
for the
sustainability
report.



Click here
for the
application
page.



EST. 1962
HALLIDAY
LIGHTING
A SITECO BRAND

sixData
A SITECO BRAND

BERGMEISTER
LEUCHTEN
A SITECO BRAND